

The Oakham Collection

Four Scottish Country Dances



Oakham Castle with All Saints Church behind.

The Oakham Collection

Four dances devised by

Robert and Margaret Senior

The Swirling Stream A 4 x 32 bar reel

The Twisted Tree A 5 x 32 bar strathspey

Wild Water An 8 x 32 bar jig

Pirongia An 8 x 32 bar reel

The Swirling Stream

A 4 x 32 bar reel for four couples in a longwise set.

3rd and 4th couples start on opposite sides.

- 1-4 1st couple dance in and down while 4th couple dance in and up, to dance advance and retire, nearer hands joined. As they retire, 2nd couple step up and 3rd couple step down to form lines of 4 and 4 across.
- 5-8 1st and 4th couples (the dancing couples) cross up/down, 1st couple retaining hands and dancing down between 4th couple as they part and dance up. 1st couple then dance between 3rd couple turning them $\frac{3}{4}$ with outer hands while 4th couple dance between 2nd couple turning them $\frac{3}{4}$ with outer hands, to end on the sides 2,(4),1,(3).
- 9-12 4th man with 1st lady also 4th lady with 1st man (the dancing couples) advance and retire across the dance.
- 13-16 The dancing couples cross the set, the two dancers from the ladies' side (4th man & 1st lady) retaining hands and passing between the other two (4th lady & 1st man). The dancing couples dance between the persons on the sides turning them $\frac{3}{4}$ with outer hands. They end 1st couple facing up between 3rd couple, and 4th couple facing down between 2nd couple.
- 17-20 1st and 4th couples advance and retire, up and down the dance.
- 21-24 1st and 4th couples turn the person opposite, once, with 2 hands, (1st lady with 4th man and 1st man with 4th lady) and fall back to the nearest side. 2,4,(1),(3).
- 25-32 All dance eight hands round and back to end on the sides 2,4,(1),(3).

Repeat from new places.

The Swirling Stream

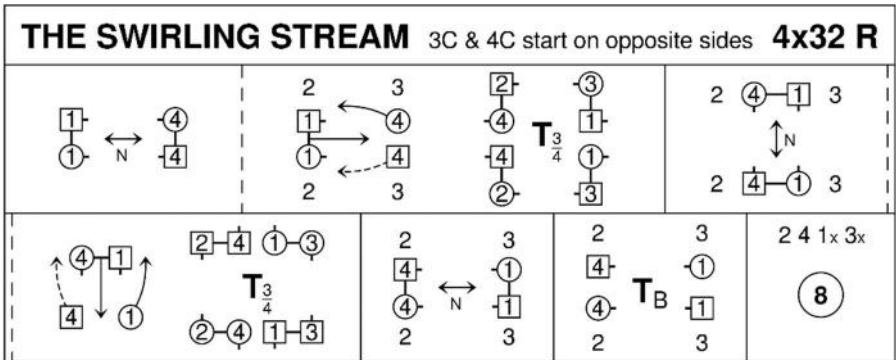

Robert & Margaret Senior, 2022

4C/4C longwise set.

Diagram Keith Rose

Music: A steady reel, with two chords to begin.

Suggested recording: 'Barry & Doreen's Continental Capers', Marian Anderson, The Sunday Class Book 1



The movement of dancers in the dance is like the motion of water in eddies in a stream.

The Twisted Tree

A 5x32 bar Strathspey for five couples in a longwise set

- 1-8 1st and 3rd couple set and cast. 2nd and 4th couple step up. 1st lady with 2nd couple, 1st man with 4th couple and 3rd lady, and 3rd man with 5th couple, dance right hands across. 2nd, 4th and 5th couple end on the sides and 1st and 3rd couple end up/down the middle of the dance with 1st man and 3rd lady facing each other.
- 9-16 1st and 3rd couple dance a reel of 4 up/down the dance, 1st man passing 3rd lady right shoulder to start. End in the same positions as at the start of the reel with 1st man and 3rd lady again facing each other, but 1st lady and 3rd man facing their nearest end.
- 17-20 1st lady with 2nd couple, 1st man with 4th couple and 3rd lady, and 3rd man with 5th couple, dance right hands across. (i.e. repeat bars 5 to 8). 2nd, 4th, and 5th couple end back on the sides. 1st and 3rd couple look for their partners on their left.
- 21-24 1st and 3rd couple turn their partners $\frac{3}{4}$ left hand into 2nd or 4th place own sides (two bar turn). All set. (2,1,4,3,5)
- 25-32 1st couple with 4th couple and 3rd couple with 5th couple dance the Espagnole to end 2,4,1,5,3.

Note: In this double Espagnole on bars 5 to 8, dancers meet shoulder to shoulder, not just within each Espagnole, but also between the two Espagnoles.

Repeat from new places.

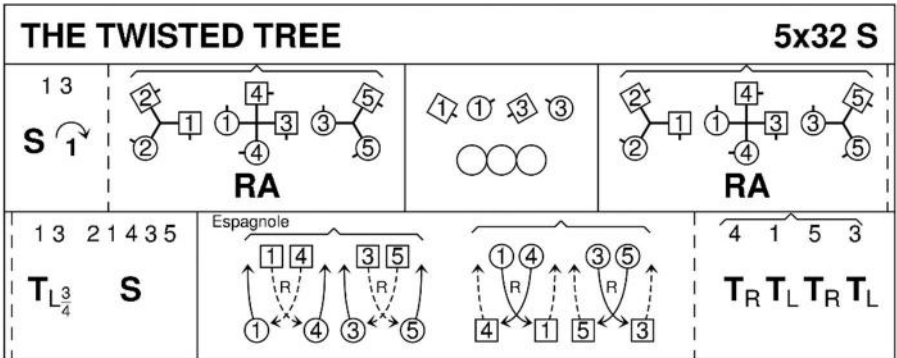

Robert & Margaret Senior, 2021

5C/5C longwise set.

Diagram Keith Rose

Music: A nice flowing 5x32 Strathspey.

Suggested recording: 'Duddingston Loch', Jim Lindsay, Recorded Highlights Vol1.



The Twisted Tree is the tree at Woolsthorpe Manor under which Isaac Newton sat when an apple falling from the tree caused him to conceive the idea of Universal Gravity. The tree was blown down in 1820, but the fallen trunk re-rooted itself. It still flourishes, but is somewhat twisted.

Wild Water

An 8 x 32 bar jig for three couples in a four couple longwise set.

- 1-8 1st couple set. 1st lady casts off two places, crosses below 3rd couple and dances up behind 3rd man. Her partner follows her but he dances up in front of 3rd lady. 1st couple dance up to second place opposite sides. 2nd couple step up on bars 5 & 6.
- 9-16 1st, 2nd and 3rd couples dance a reel of 3 on the sides, 1st couple giving left shoulder to 2nd couple to start.
- 17-24 1st and 2nd couples dance a ladies' chain, end with 1st man facing out on ladies' side.
- 25-32 1st man casts off behind 3rd lady followed by his partner and they dance to own sides below 3rd couple; 1st man pulls right shoulder back to face in. They turn right hand and lead up the middle to 2nd place own sides.

Repeat from 2nd place.

Note: The reels of 3 and the ladies' chain should each take the full 8 bars so that 1st couple can dance through 2nd place (bars 24,25) without a pause.

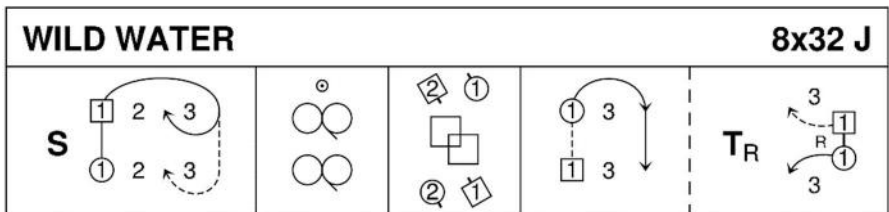

Robert Senior, 2022

3C/4C longwise set.

Diagram Keith Rose.

A steady 8x32 Jig.

Suggested recording: 'The Drumlins of Down', Marian Anderson, Diamond Jubilee Dances - Belfast Branch.



Pirongia

An 8 x 32 bar reel for 3 couples in a 4 couple longwise set.

- 1-8 1st couple set and turn right hand whilst moving down to face out in 2nd place own sides (2nd couple step up 3 & 4); 1st couple cast to their right to finish in lines across, 1st man between 2nd couple facing down and 1st lady between 3rd couple facing up.
- 9-16 All 3 couples set. 1st couple change places with right hand, and dance up or down through the standing couples. They then cast right to dance in through 2nd place own sides, passing each other left shoulder to face 1st corners.
- 17-24 1st couple turn 1st corner with right hand, pass partner right shoulder, turn 2nd corner with right hand, and pass partner right shoulder to 2nd place own sides.
- 25-32 2nd, 1st & 3rd couples circle 6 hands round and back.
Repeat from new places.

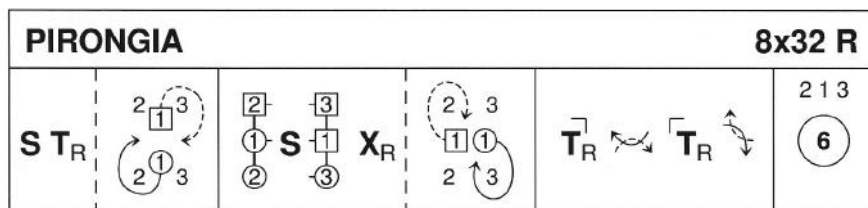

© 2016 Keith Rose

Diagram Keith Rose.

This dance was first published in 'The Sunday Class Dance Book 2'

Marian Anderson wrote the original tune for this dance – 'Brock's Midnight Bin Bash'. The Sunday Class Dance Book 2 contains the sheet music for this tune and the associated CD has recorded music for the dance.

Pirongia is a mountain in New Zealand where the devisor's grandchildren lived when they were young.

The devisors would like to thank members of Oakham Scottish Country Dance Club for helping to develop and test these dances.

They also wish to thank Keith Rose for the crib diagrams, and Amanda Peart for permission to reprint 'Pirongia' from The Sunday Class Book 2.

The CDs mentioned in this booklet are available from <http://www.thesundayclass.org.uk/>

For copies of this booklet, email randm.senior@tiscali.co.uk

Robert & Margaret Senior February 2023.